

13" Manual Slide P/N 6540 shown,
CNC version also available



2-axis X/Y Machine Slide

P/N 6540 (6541) Manual

P/N 6545 (6546) CNC-Ready

P/N 6540-18 (6541-18) Manual

P/N 6545-18 (6546-18) CNC-Ready

The Sherline industrial X/Y slide was developed from components of the X/Y base of the Sherline miniature milling machine. Like a milling machine, the movements are designated as the X-axis and the Y-axis. The Y-axis moves the table in and out. The X-axis moves the table from side to side. If the table were to be mounted vertically, the side-to-side travel would still be called the X-axis, but the vertical travel would then be called the Z-axis. The X/Y slide has two table sizes available: 13" and 18".

Mounting the X/Y Slide

The base offers two methods of mounting to your fixture. On the bottom are four 1/4-20 holes for through-fixture mounting. If this is not practical, the base can be attached to your fixture using angle clamps in the groove that surrounds the base. (Optional angle clamps for 10-32 screws are available from Sherline as P/N 35580.)

Using the Handwheels

The handwheels on the manual versions are marked in .001" (or .01 mm) increments. One revolution of the inch handwheels will move the table .050", while one revolution of the metric handwheels will move the table 1 mm. The handwheels on manual models have two preloaded ball bearings to provide smooth operation with minimum end play. The preload has been adjusted at the factory, and a small amount of thread locking compound has been used to keep it in place.

Adjusting the Preload on the Handwheel or Coupling Bearings

Should end play occur in the handwheel or coupling, it can be eliminated by tightening the preload nut against the bearing. The preload nut is on the end of the leadscrew against the bearing of the handwheel or stepper motor mount. To keep the leadscrew from turning while tightening the nut, insert a hex key through the hole in the stepper motor mount and into the head of the set screw as shown in Figure 1 below. This will keep the coupling from turning while you adjust the nut. After adjusting, place a small amount of thread locking compound such as Loctite® on the threads and allow capillary action to draw it in. Thread locking

compound has been applied to the nut from the factory, so it may be difficult to break it loose from the leadscrew. If the nut doesn't come loose easily, it is possible to break the coupling at the dampening notches. An alternative method would be to hold the leadscrew with a clamping device (such as locking pliers), making sure to protect the threads with plastic or hard wood. Don't forget that the Y-axis leadscrew has a left-hand thread.

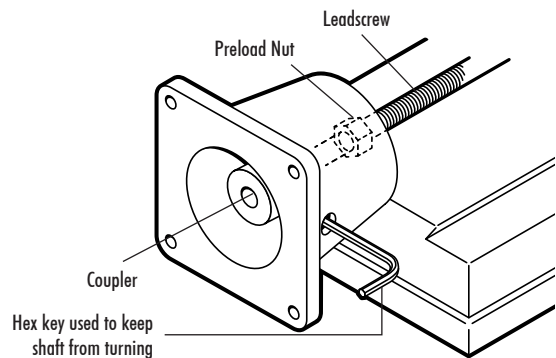

FIGURE 1—Using a hex key to keep the shaft from rotating while adjusting the preload nut. The hex key adjustment hole may be located on either side depending on the axis. On older models the hole may be on the bottom instead of the side as is shown here.

Backlash Adjustment

The leadscrews have a backlash adjustment on both the X- and Y-axes. Backlash is the amount the handwheel can be turned before the slide starts to move when changing directions. This is normal on all threaded leadscrews and is accounted for by always approaching your final setting from the same direction.

The factory setting for backlash is between .003" and .005" (.08 mm to .12 mm). Should wear occur, this setting can be maintained by adjusting anti-backlash nuts. These nuts are located on the handwheel ends of the saddle. The nuts are secured by button head screws that hold a star gear. This gear interlocks with teeth on the anti-backlash nuts to keep them from turning.

To adjust backlash, simply loosen the button head screw that locks the star gear. Rotate the anti-backlash nut clockwise on the X-axis and counterclockwise on the Y-axis until snug. After adjustment, retighten the button head screw.

Putting a Flat on the Stepper Motor Shaft

Stepper motors ordered from Sherline come with a flat on each shaft where the coupling set screw is to be tightened. If you use a stepper motor from another source it is important that you machine or file a flat in the appropriate location before installation. If the set screw is not tightened against a flat, it can upset the surface of the shaft, making it impossible to remove from the coupling. The attached drawing of the mount shows the location for the flat on the motor shaft. The center of the flat will occur .515" (13.1 mm) from the mounting surface of the stepper motor.

Attaching a Stepper Motor to the Mount

Insert the stepper motor shaft into the hole in the end of the coupling after first making sure the coupling set screw is backed off enough that it will not bind. Rotate the coupling to align the set screw with the hole in the motor mount. Install the four 8-32 bolts provided to secure the motor to the mount. Insert a hex key through the hole in the motor mount and tighten the set screw in the coupling to secure it to the motor shaft. Scribe a witness mark on the back of your stepper motor for reference.

CAUTION: When using a handwheel to drive the stepper motor shaft for manual control, make sure to unplug the stepper motor from the system. Cranking a stepper motor by hand can cause it to act as a generator. If it is connected to the controller, the current generated could damage the circuits.

It should also be noted that stepper motors are not sealed, and they are not intended to be used in a coolant-soaked environment. Electrical connections should be shielded from flying coolant, and cables should be protected from hot chips.

Locking the Saddle and Table

Locks are provided on both the X- and Y-axes. To lock the X-axis in position, tighten the socket head screw in the center of the small barrel-shaped lock on the front of the saddle. To lock the Y-axis in position, tighten the thumbscrew on the side of the saddle. This pushes a small, angled Teflon piece against the side of the dovetail on the base to provide a friction lock. Do not overtighten!

Adjusting Gibs to Eliminate Side-to-Side Play

Gibs are wedge-shaped plastic spacers that ride between the saddle and base dovetail and between the table and saddle dovetail. As wear occurs, the gibs can be pushed further into the gap between moving surfaces to eliminate side-to-side play. To adjust the gib, the set screw holding the gib lock (an "L" shaped wire at the end of the gib) is loosened. The gib is then pressed further into the gap until the desired adjustment is obtained. The set screw is then retightened to lock the gib in position. Note that this wire gib lock must be in place, as it is what makes the gib move with the saddle or table. If it is left out or the locking set screw

is not tightened, the gib can become wedged between the moving surfaces, making movement difficult or impossible.

Cleaning and Lubrication

The machine slides should be kept clean and lubricated with a light machine oil or grease. New units come from the factory lubricated with a Teflon-based synthetic grease that works exceptionally well. It is available in small quantities through auto parts stores under several major brand names. Leadscrews are lubricated as needed with light machine oil. The leadscrews and sliding surfaces should be kept free of chips. If coolant is used during a cutting operation, it should be wiped off after use and fresh lubrication applied.

Thank you,
Sherline Products Inc.

13" Table Specifications

Table size: 13" x 2.75" (330 mm x 70 mm)

Table height: 2.8" (71.1 mm)

X-axis travel: 9.0" (228 mm)

Y-axis travel: 4.1" (104 mm)

Hold-down provision: 2 T-slots*

Handwheel graduations: .001" on inch versions, .01 mm on metric

Overall weight (6540/6541): 8 lb (3.6 kg)

Overall weight (6545/6546): 11.6 lb (5.3 kg) (without stepper motors)
(Stepper motors add 1.7 lb each)

18" Table Specifications

Table size: 18" x 2.75" (458 mm x 70 mm)

Table height: 2.8" (71.1 mm)

X-axis travel: 13.38" (340 mm)

Y-axis travel: 4.1" (104 mm)

Hold-down provision: 2 T-slots*

Handwheel graduations: .001" on inch versions, .01 mm on metric

Overall weight (6540-18/6541-18): 10 lb (4.5 kg)

Overall weight (6545-18/6546-18): 13.6 lb (6.18 kg) (without stepper motors)

(Stepper motors add 1.7 lb each)

*Note: Sherline 10-32 T-nuts that fit the table T-slots are available in a package of 10 as P/N 3056.

MANUAL SLIDES—EXPLODED VIEW

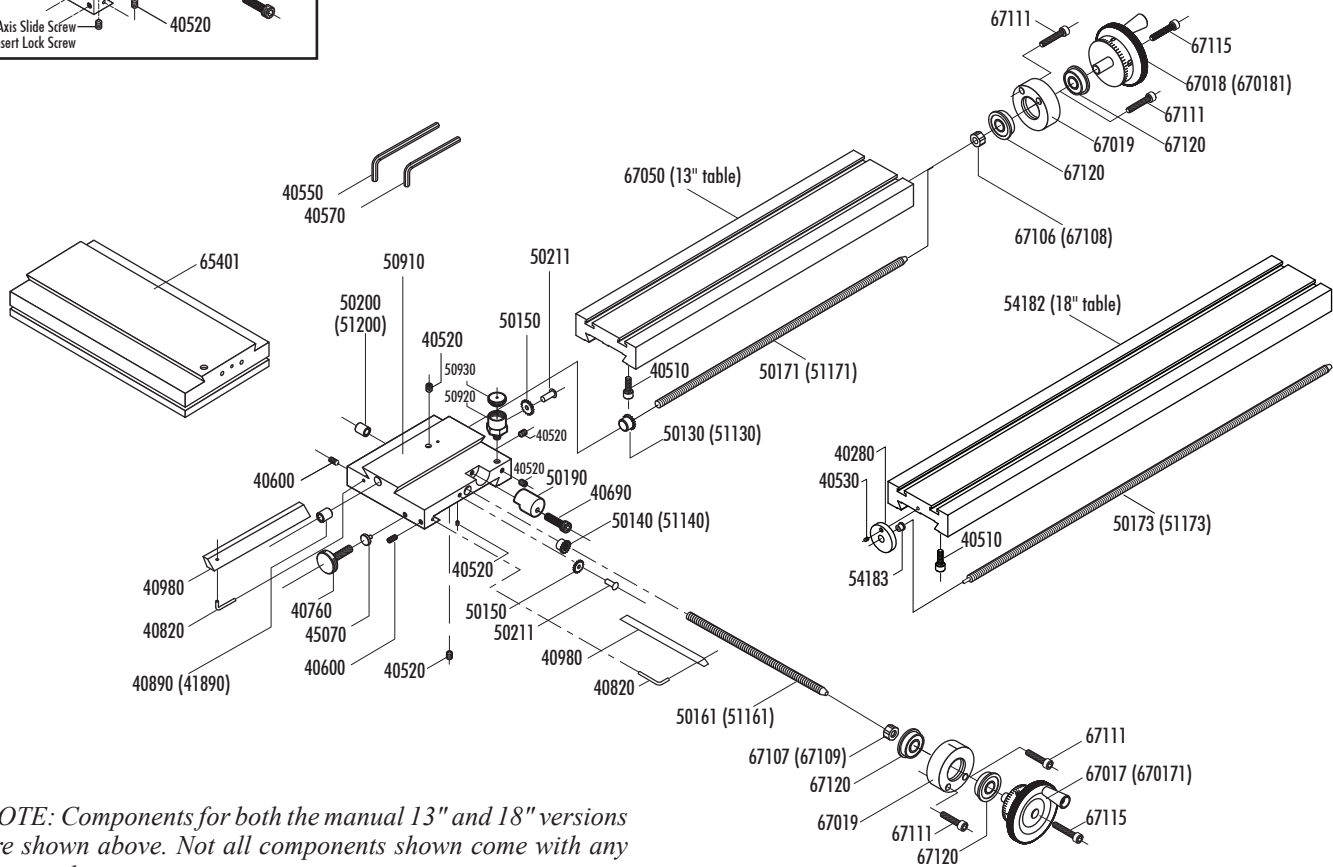
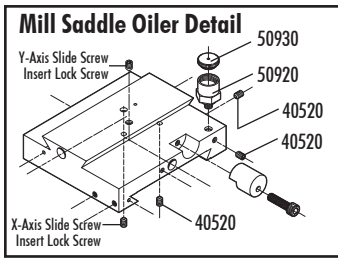

NOTE: Components for both the manual 13" and 18" versions are shown above. Not all components shown come with any one machine.

Parts List

NO. REQ.	PART NO.	DESCRIPTION	NO. REQ.	PART NO.	DESCRIPTION
1	40280	Thrust collar (18" table only)	1	50173	18" X-axis leadscrew, inch (P/N 51173, metric)
5	40520	10-32 x 3/16" socket head cap screw	1	50190	Table lock
2	40510	10-32 x 3/8" socket head cap screw	1	50200	Y-axis slide screw nut, inch (51200, metric)
1	40530	5-40 X 3/8" socket head cap screw (18" table only)	2	50211	Button head socket head screw
1	40550	5/32" hex key	1	50910	Mill saddle
1	40570	3/32" hex key	1	54182	18" mill table
2	40600	10-32 X 1/4" Flat PT Set Screw	1	54183	18" Table leadscrew bushing
1	40690	10-32 x 3/4" socket head cap screw	1	65401	Industrial X/Y base
1	40760	Thumbscrew	1	67017	Y-axis 2" Industrial handwheel, inch (P/N 670171, metric)
2	40820	Gib lock	1	67018	X-axis 2" Industrial handwheel, inch (P/N 670181, metric)
1	40890	X-axis slide screw nut, inch (P/N 41890, metric)	2	67019	Industrial handwheel thrust collar
2	40980	Gib	1	67050	13" mill table
1	45070	Teflon® lock	1	67106	X-axis preload nut (RH), inch (P/N 67108, metric)
1	50130	X-axis anti-backlash nut, inch (P/N 51130, metric)	1	67107	Y-axis preload nut (LH), inch (P/N 67109, metric)
1	50140	Y-axis anti-backlash nut, inch (P/N 51140, metric)	4	67111	8-32 x 3/4" socket head cap screw
2	50150	Star gear	2	67115	5-40 x 7/8" socket head cap screw
1	50161	Y-axis leadscrew, inch (P/N 51161, metric)	4	67120	CNC preload bearing
1	50171	X-axis leadscrew, inch (P/N 51171, metric)			

CNC SLIDES—EXPLODED VIEW

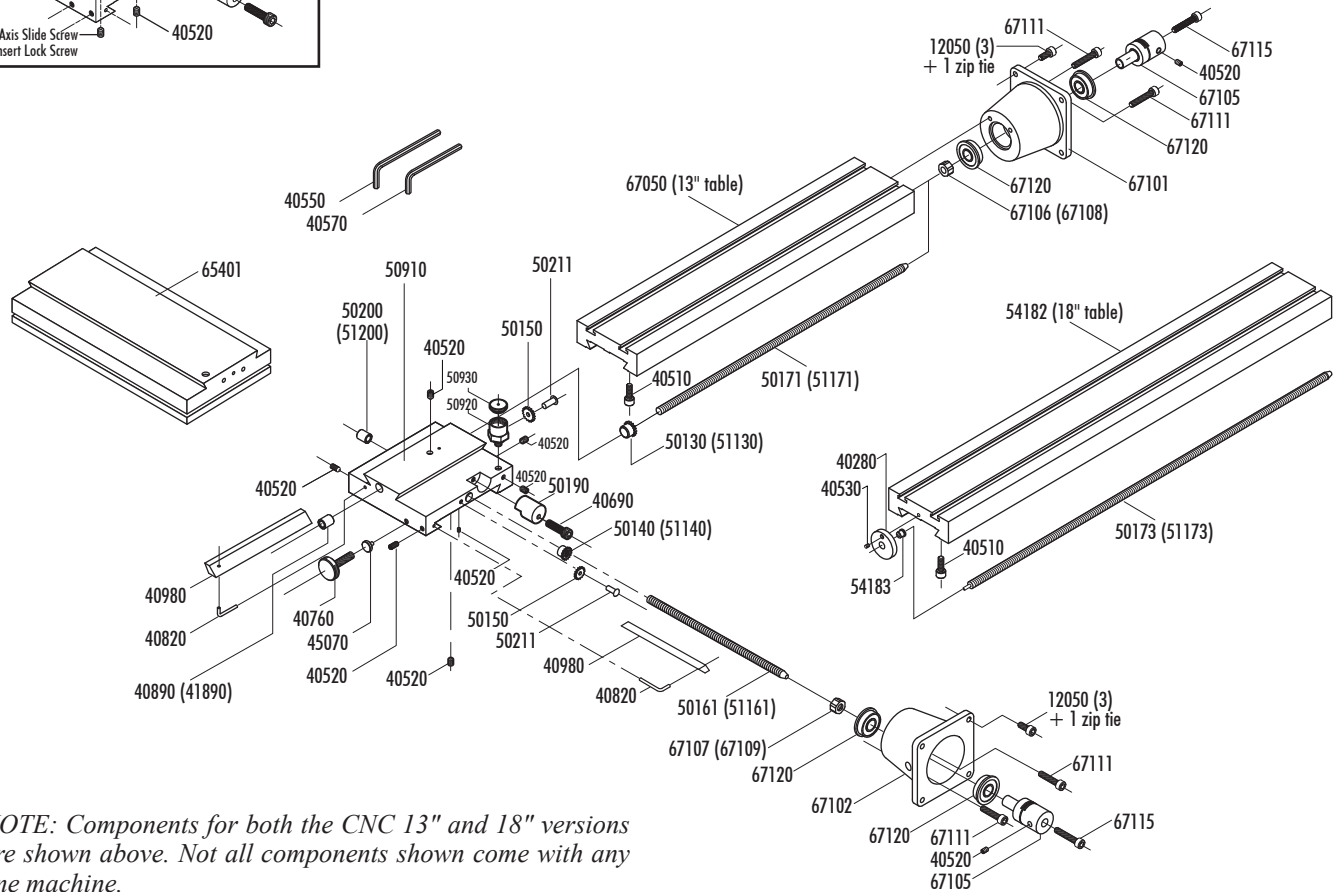
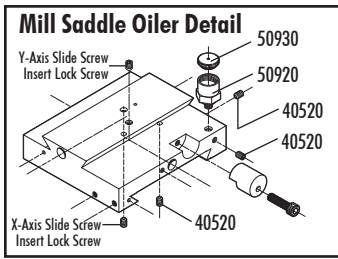

NOTE: Components for both the CNC 13" and 18" versions are shown above. Not all components shown come with any one machine.

Parts List

NO. REQ.	PART NO.	DESCRIPTION	NO. REQ.	PART NO.	DESCRIPTION
6	12050	8-32 x 3/8" socket head cap screw (+ 2 zip ties)	1	50173	18" X-axis leadscrew, inch (P/N 51173, metric)
1	40280	Thrust collar (18" table only)	1	50190	Table lock
6	40520	10-32 x 3/16" socket head cap screw	1	50200	Y-axis slide screw nut, inch (51200, metric)
2	40510	10-32 x 3/8" socket head cap screw	2	50211	Button head socket head screw
1	40530	5-40 X 3/8" socket head cap screw (18" table only)	1	50910	Mill saddle
1	40550	5/32" hex key	1	54182	18" mill table
1	40570	3/32" hex key	1	54183	18" Table leadscrew bushing
2	40600	10-32 X 1/4" Flat PT Set Screw	1	65401	Industrial X/Y base
1	40690	10-32 x 3/4" socket head cap screw	2	67102	Stepper motor mounts
1	40760	Thumbscrew	1	67050	13" mill table
2	40820	Gib lock	2	67105	CNC coupling
1	40890	X-axis slide screw nut, inch (P/N 41890, metric)	1	67106	X-axis preload nut (RH), inch (P/N 67108, metric)
2	40980	Gib	1	67107	Y-axis preload nut (LH), inch (P/N 67109, metric)
1	45070	Teflon® lock	4	67111	8-32 x 3/4" socket head cap screw
1	50130	X-axis anti-backlash nut, inch (P/N 51130, metric)	2	67115	5-40 x 7/8" socket head cap screw
1	50140	Y-axis anti-backlash nut, inch (P/N 51140, metric)	4	67120	CNC preload bearing
2	50150	Star gear			
1	50161	Y-axis leadscrew, inch (P/N 51161, metric)			
1	50171	X-axis leadscrew, inch (P/N 51171, metric)			